

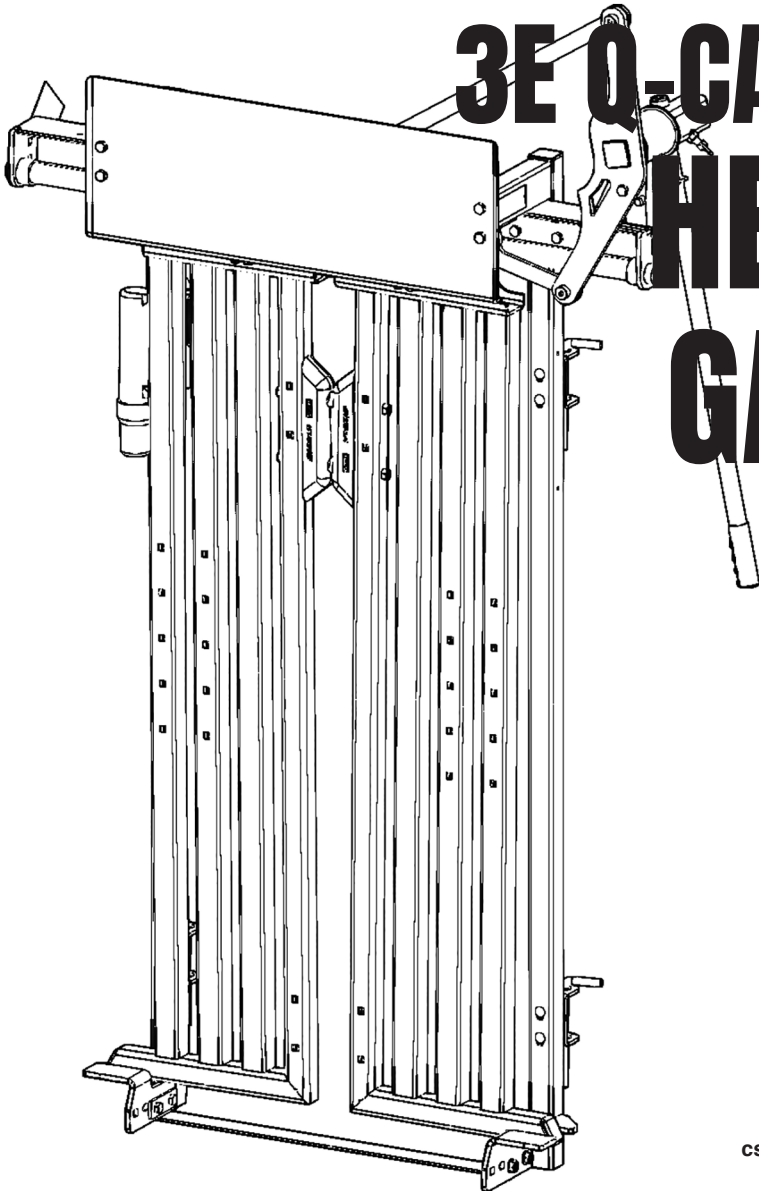

ARROWQUIP

PRODUCT MANUAL



3E Q-CATCH[®] HEAD GATE

QCHG
OCTOBER 2021

1-877-275-6075
cs@arrowquip.com
arrowquip.com

CONTENTS

Safety Precautions	1
3E Q-Catch Head Gate Assembly	2
Emergency Head Gate Release	2
Recommended Maintenance	4
Regular Maintenance (Every 6 Months)	4
When Necessary	5
Friction Lock Maintenance	6
Troubleshooting Guide	6
Warranty	7
3E Q-Catch Head Gate Series Add-ons	8
Manual Head Restraint: 3rd Generation Head Holder / Chin Bar	8

PLEASE FOLLOW ALL SAFETY INSTRUCTIONS PROVIDED IN THIS MANUAL BEFORE OPERATION. ARROWQUIP DOES NOT ACCEPT RESPONSIBILITY FOR ANY ACCIDENTS OR INJURY WHEN THIS SAFETY MANUAL HAS NOT BEEN READ IN FULL AND KEPT WITH THE PRODUCT AT ALL TIMES. OPERATORS OF THIS PRODUCT TAKE AND ACCEPT RESPONSIBILITY FOR ANY HARM OR INJURY TO THE ANIMAL OR OPERATOR WHEN IT PERTAINS TO HOW THE EQUIPMENT IS USED AND MAINTAINED.

Please keep this manual for frequent reference and to pass on to new users or owners.

SAFETY PRECAUTIONS

PLEASE FOLLOW ALL SAFETY PRECAUTIONS OUTLINED HEREIN. ANY HARM TO THE ANIMAL OR INJURY TO THE OPERATOR WHICH OCCURS DUE TO HOW THE PRODUCT IS OPERATED, OR RESULTING FROM A LACK OF SAFETY PRECAUTIONS ARE THE SOLE RESPONSIBILITY OF THE OPERATOR.

All farm machinery and equipment are potentially dangerous. Careless use of any Arrowquip livestock equipment may cause injury or damage to persons, cattle, or property. Arrowquip has taken precautions in the design and manufacturing of this product to ensure that it is safe and user-friendly. Therefore, the user must assume all responsibility and risk associated with the possession and use of the cattle squeeze chute.



WARNING: READ BELOW BEFORE OPERATION.

Ensure the operator understands the contents of this manual before using the cattle equipment.

1. **DO NOT** wear loose-fitted clothing.
2. **DO NOT** stand in front of the head gate while operator is moving the cattle through.
3. **DO NOT ALLOW CHILDREN UNDER THE AGE OF 18 NEAR AN OPERATING MACHINE.**
4. Follow safe cattle handling procedures in other areas of the yard so that cattle are more docile in the head gate.
5. **DO NOT** make any modifications to Arrowquip equipment. Non-factory modifications to the equipment can reduce the safety for the operator & livestock, and void warranty.

3E Q-CATCH HEAD GATE ASSEMBLY

Your head gate will arrive fully assembled and ready for use. However, if you need to disassemble your head gate for any reason, the following guide will help you to properly reassemble it.

ASSEMBLING THE Q-CATCH HEAD GATE

Fit the mechanism parts as shown in the diagram below.

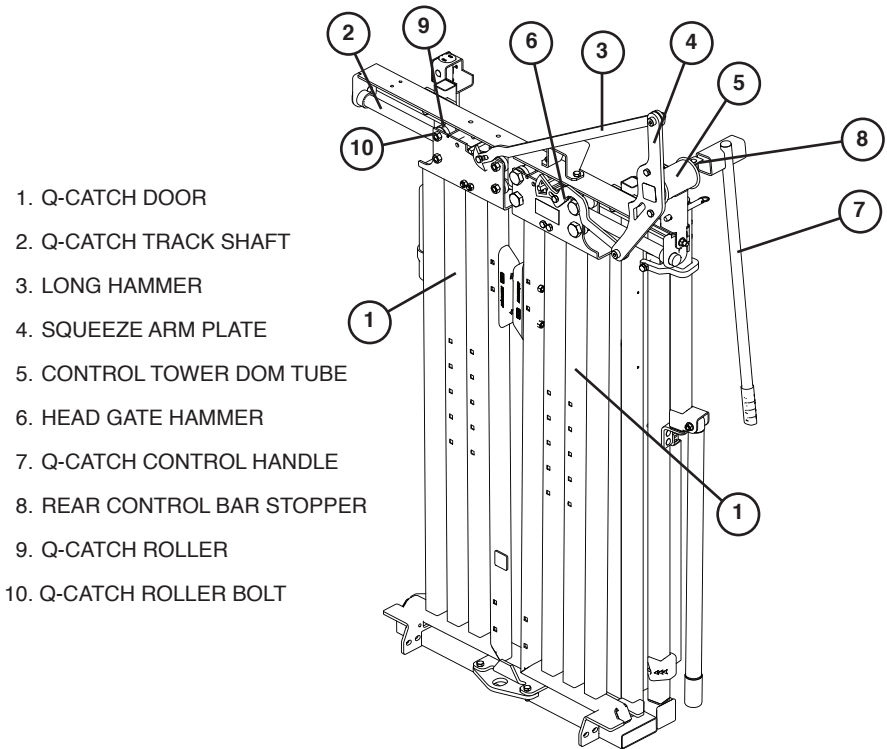

EMERGENCY HEAD GATE RELEASE

Arrowquip equipment is designed to ensure the safety of both animal and operator. **With proper maintenance and lubrication, the head gate will not jam under pressure.** However, in the rare event that an animal becomes stuck in the head gate, the following guidelines will ensure you are able to release your animal quickly and safely.

REQUIRED TOOLS

- Screw Driver/Pry Bar

STEPS TO RELEASE LOCK

- 1** Go to the offside of the chute, to ensure you will not be hit by the head gate handle. If your chute is designed for offside operation, you will need to go to the nearside of the chute.
- 2** Place screwdriver/pry bar under bottom head gate roller on the outer edge of the door.
(This is the side with the "L" curve, not the straight side.)
- 3** Insert screwdriver/pry bar into the small space above the spring in the head gate lock plate.

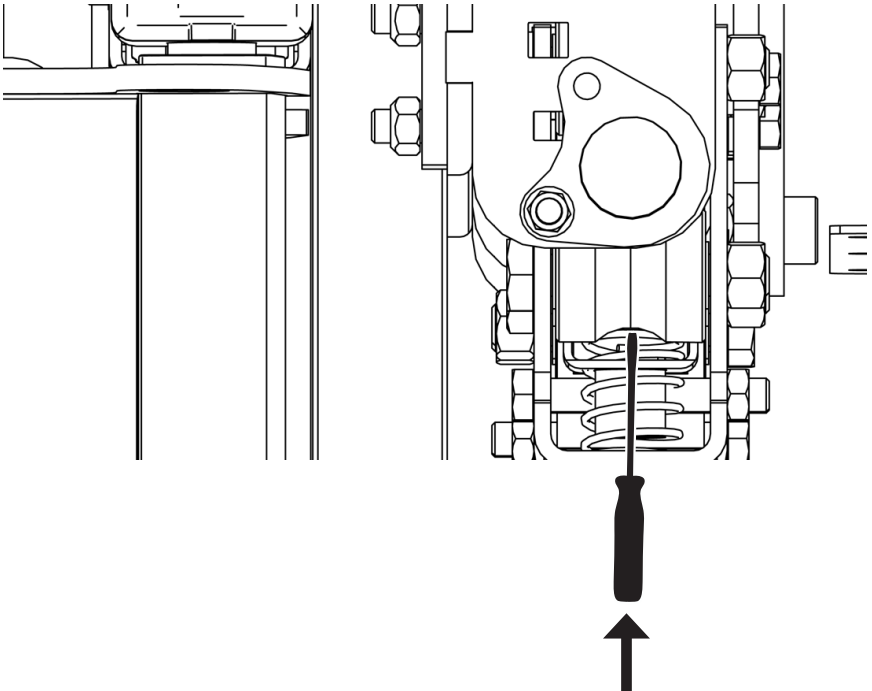
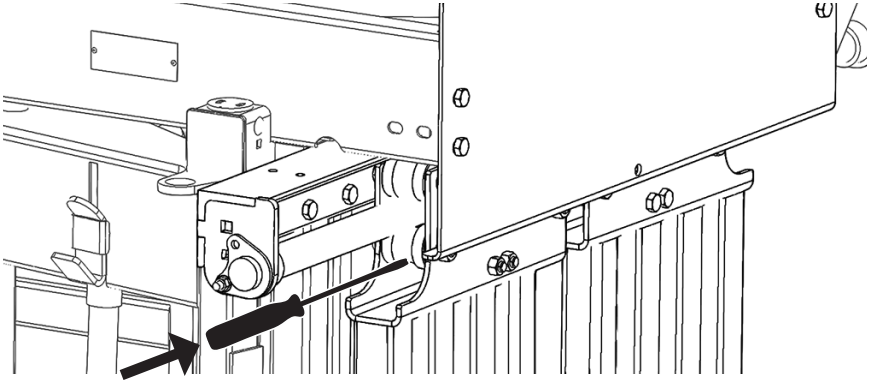

- 4** Tilt the screwdriver/pry bar up and into the head gate roller. This will push down the spring, releasing the locking mechanism on the head gate door.

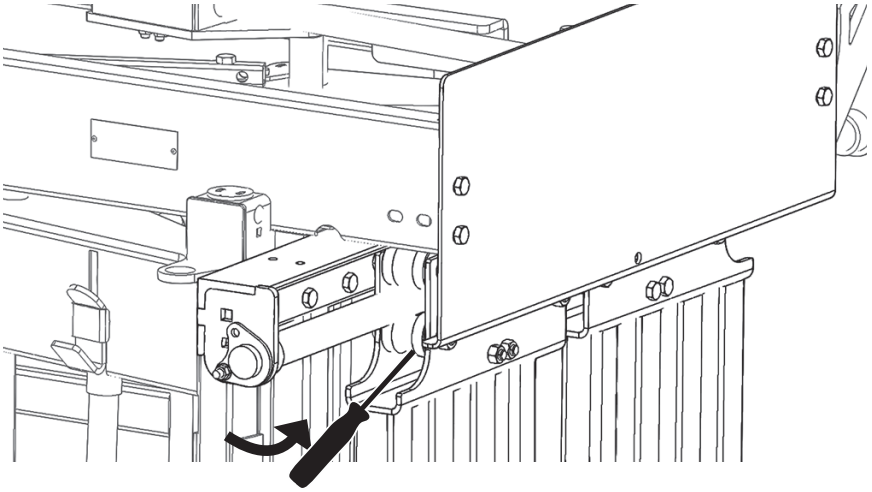

RECOMMENDED MAINTENANCE

All Arrowquip Products are made with precision parts to require minimal maintenance. However, regular maintenance will keep your equipment running smoothly and safely.

REGULAR MAINTENANCE (EVERY 6 MONTHS)

- ✓ Inspect the head gate.
 - a. Bolts on the head gate hammers should be tensioned correctly. There should be enough play for the hammers to move freely in their slots.

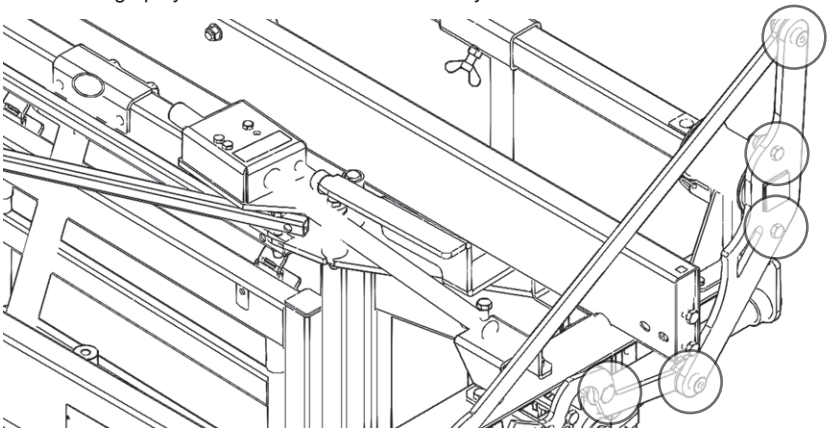

- b. You should feel the head gate rollers moving when you open the head gate. The rollers should be tight enough to be moved by hand, but not over-tight to cause the rollers to bind.

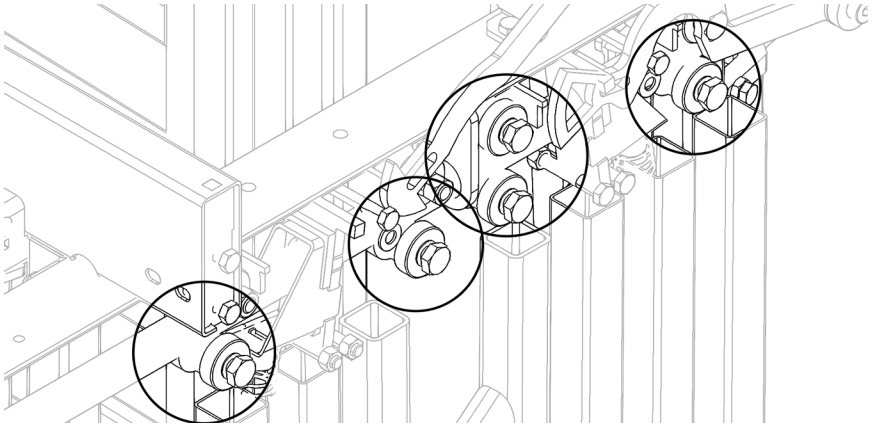

- ✓ Clean bottom head gate door track to prevent dirt-build-up.

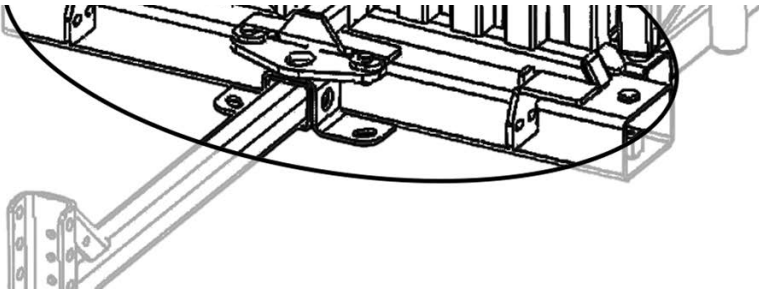

WHEN NECESSARY

- ✓ If needed, clean and lubricate the Q-Catch track shaft.
 - a. To clean: Use brake cleaner to remove build-up and degrease the shaft. Open and close (or squeeze and un-squeeze) to clean the entire shaft.
 - b. To lubricate: Spray WD-40 Dry Lube on a rag. Open or squeeze. Wipe shaft. Close or un-squeeze. Wipe shaft. Open and close (or squeeze and un-squeeze) a few times to work the lubricant in.

FRICION LOCK MAINTENANCE - IF HEAD GATE IS STICKING OR HARD TO RELEASE

1. Clean the head gate shaft with brake cleaner.
2. Apply WD-40 Dry Lube sparingly WITH A CLOTH to the Head Gate shaft, only when necessary.

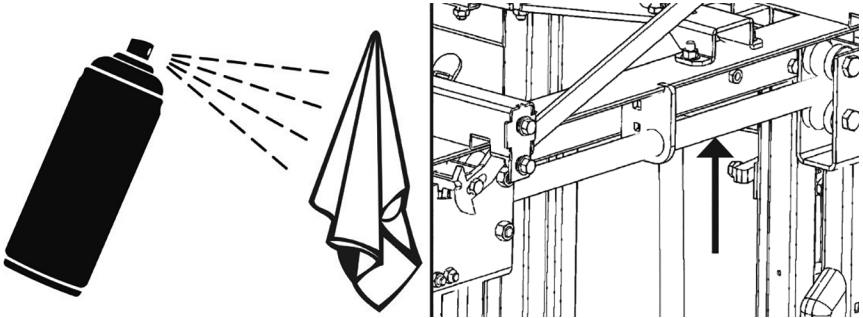

3. Use WD-40 Dry Lube only.
 4. Use of other lubricants, including regular WD-40 may cause malfunction or slipping.
- Contact 1-877-275-6075 for assistance.

TROUBLESHOOTING GUIDE

If you have a problem with your 3E Q-Catch head gate, please consider the following tips or call us at 1-877-275-6075.

1. Make sure the unit is situated on level ground or base.
2. If head gate has minimal use over extended periods, this may cause head gate doors to become stiff to operate and/or difficult to release. This can be easily fixed by lubrication of the rollers and the Q-Catch track shaft with WD-40 Dry Lube.
 - a. To lubricate the Q-Catch track shaft, wipe shaft with a rag sprayed with WD-40 Dry Lube. Repeat with head gate doors closed and open to properly lubricate the entire shaft.
 - b. Open and close the head gate a few times to work the lubricant in.
3. Make sure head gate door tracks are free of debris.
4. Keep floor clean. Excess build-up of manure or dirt inside chute can cause the squeeze and head gate to malfunction.
5. Ensure bolts on the head gate are tightened correctly.
 - a. Too tight will cause the locking and releasing of head gate doors to malfunction.
 - b. Too loose will cause premature wear on head gate parts.

- c. On the head gate, there is a short hammer and a long hammer between the handle pivot and doors. These two hammers have a slot in them – check that there is free movement for the bolt to move the entire length of this slot, and the lock nuts are correctly tightened.
 - d. The door hammers also contact the release pins on the lock plates when the head gate handle is pulled back. Ensure there is an air gap between levers and release pins when head gate is being pushed or in an idle position.
6. Check nuts and bolts on items and ensure that they are tightened correctly, and are not binding.
7. All lock boxes and pivot points should be lubricated as needed with WD-40 Dry Lube.

WARRANTY

Your product must be registered to claim warranty, and to ensure that Arrowquip has the required information to contact you in the event of a product or part recall. Any owner who fails to register their product warranty with Arrowquip through their Authorized Arrowquip Dealer voluntarily voids their warranty. Arrowquip will repair or replace products or parts of a product that prove defective due to manufacturer defect during the Warranty Period, at their sole discretion. This excludes defects resulting from normal wear and tear or product misuse. Warranty does not cover corrosion. NOTE: Any modification, in any fashion, to any Arrowquip equipment immediately voids the product warranty. This includes the parts contained therein.

Eg. If a modification is made to the squeeze mechanism in a squeeze chute, and the sternum bar is bent afterwards, warranty for the damaged part, the sternum bar, contained in the modified equipment, the squeeze chute, is void. In addition, any remaining warranty for the squeeze chute and other parts contained therein, including, but not limited to, the head gate, locking system, Q-Catch system, and rollers, is null and void.

REGISTER FOR WARRANTY NOW:

Online: arrowquip.com/product-registration

Phone: 1-877-275-6075 | **Email:** cs@arrowquip.com

3E Q-CATCH HEAD GATE SERIES ADD-ONS

3rd GENERATION Q-CATCH HEAD HOLDER

For complete information, read the Head Restraint manual.

Requirements:

- 2 people
- 3/4" wrench

Installation:

- 1** a. Insert 4x1/2-13x3" carriage bolts through the head gate door from inside the chute.
b. Align the head holder to the slots in the head gate according to your desired height.

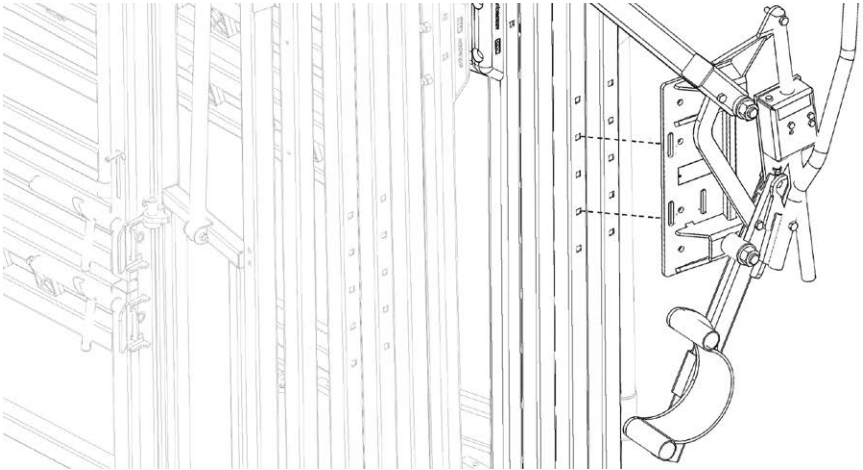

- 2** Secure the head holder with 4 bolts.

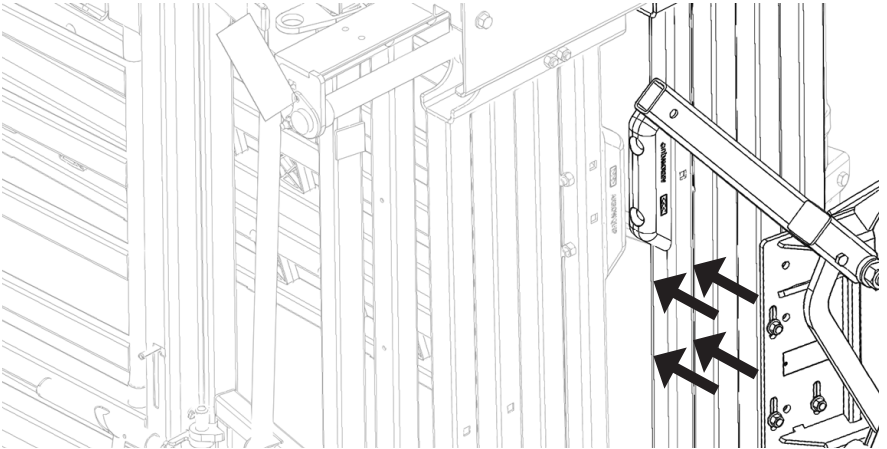

Safety Precautions:

1. Ensure that the head holder remains open until required to hold the animal's head.
2. If not in use, use detent pin to hold the head holder in place.

Maintenance:

1. Add grease through the grease nipples **as needed**.
2. Every 6 months:
 - a. Check bolts to ensure they are tightened properly.
 - b. Spray brake cleaner on a rag and wipe the lockbox shaft while opening and closing the head holder.



ARROWQUIP

If you have any questions regarding your product or require assistance, please contact Arrowquip's Client Care Team at 1-877-275-6075 or by email at cs@arrowquip.com.