

BULL CATCHER ADAPTOR INSTALLATION INSTRUCTIONS

REQUIRED MATERIALS

- 1x 2011275 Bull Catcher Sheet Metal Left-Hand
- 1x 2011277 Bull Catcher Sheet Metal Right-Hand
- 8x 7002295 1/2-13 x 3" Carriage Bolt
- 8x 7001812 1/2-13 Flange Nut

REQUIRED TOOLS

- 2x 3/4 wrench

IMPORTANT NOTES

- Left and Right-Hand are determined by looking at the head gate from inside the chute.
- Do not remove the plastic Neck Yoke pieces on the Head Gate doors.

INSTRUCTIONS

1. Ensure all parts are accounted for and identify each.
2. Open Head Gate doors until approximately 3/4 open.

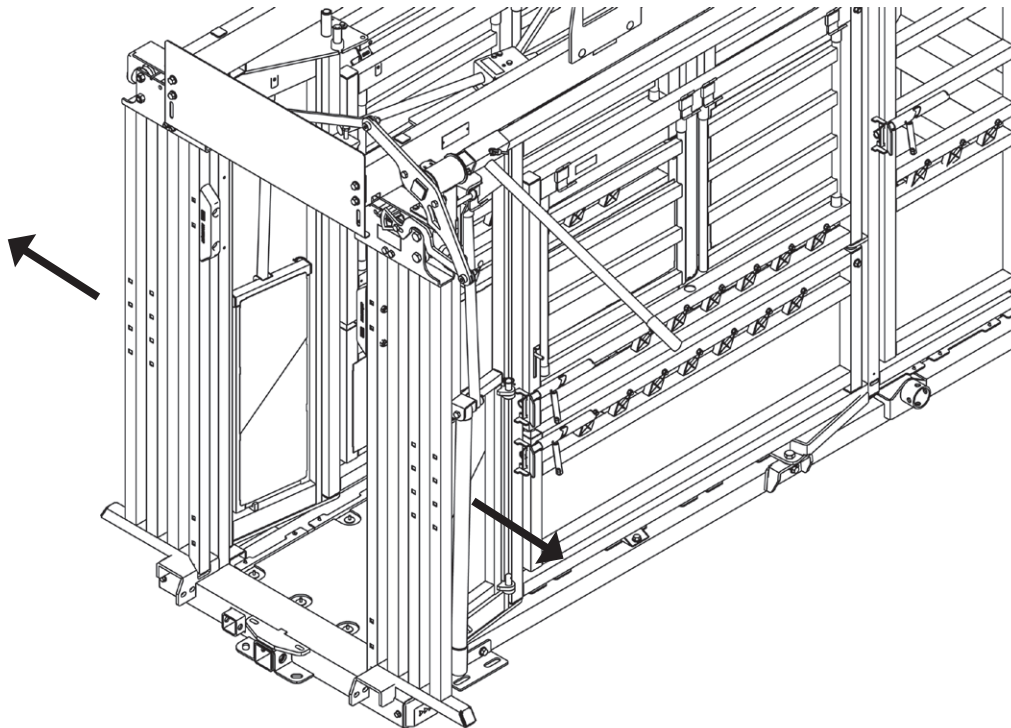

3. Slide the Left-Hand Bull Catcher Sheet Metal onto the Left-Hand Head Gate Door.

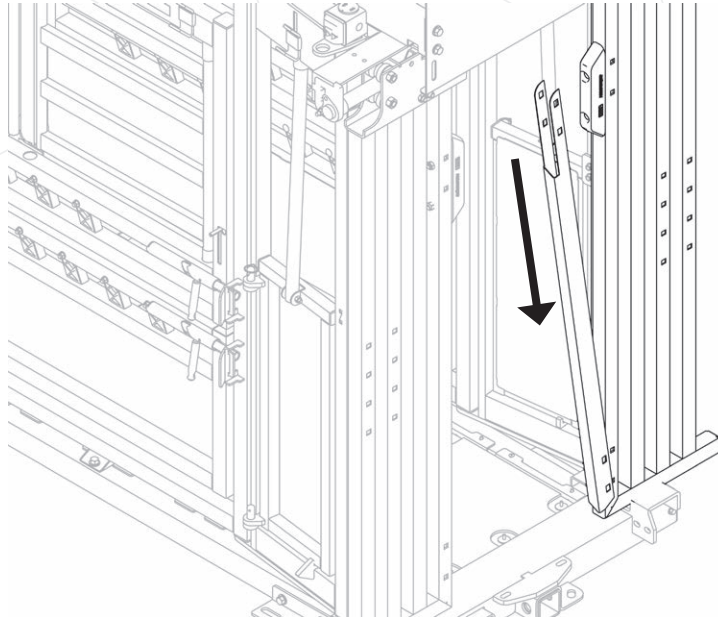

4. Secure Left-Hand Bull Catcher Sheet Metal on the Head Gate Door with 4x Carriage Bolts and 4x Flange Nuts.

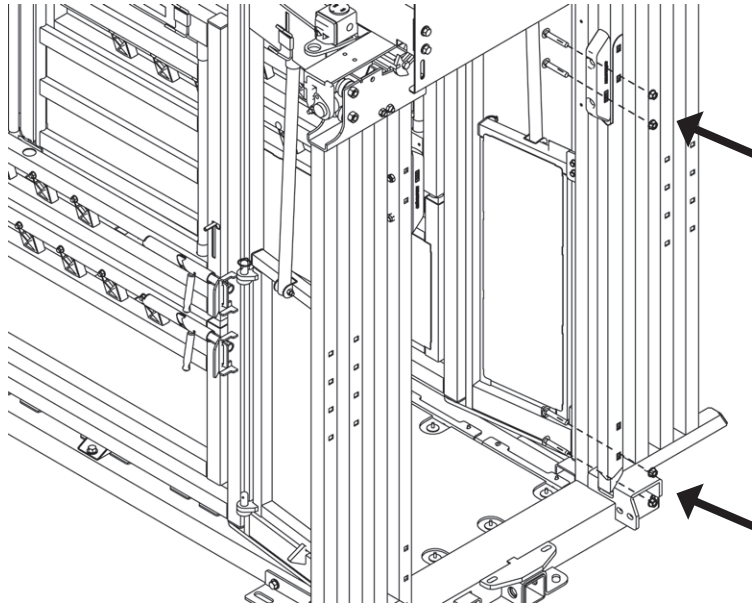

5. Slide the Right-Hand Bull Catcher Sheet Metal onto the Right-Hand Head Gate Door.

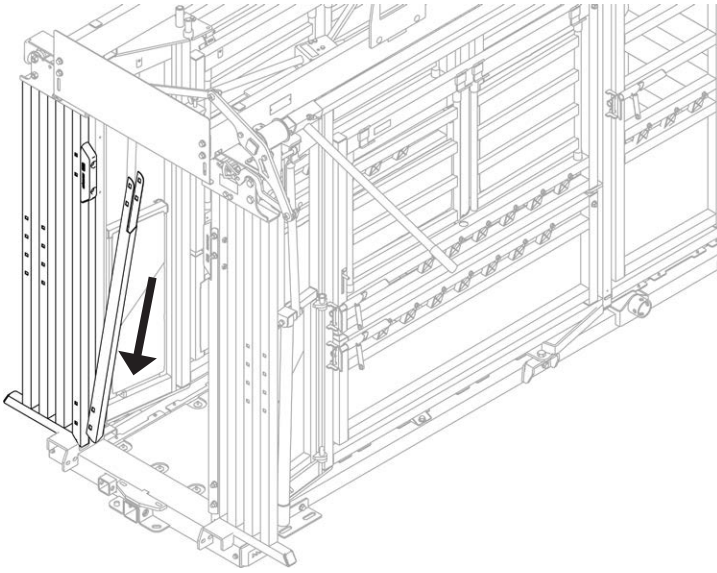

6. Secure the Right-Hand Bull Catcher Sheet Metal on the Head Gate with 4x Carriage Bolts and 4x Flange Nuts.

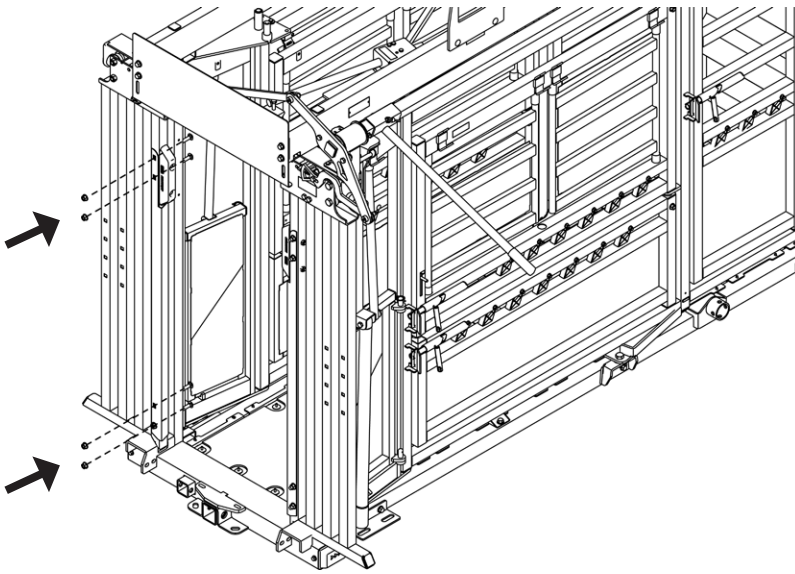

7. Ensure all nuts and bolts are tightened properly.

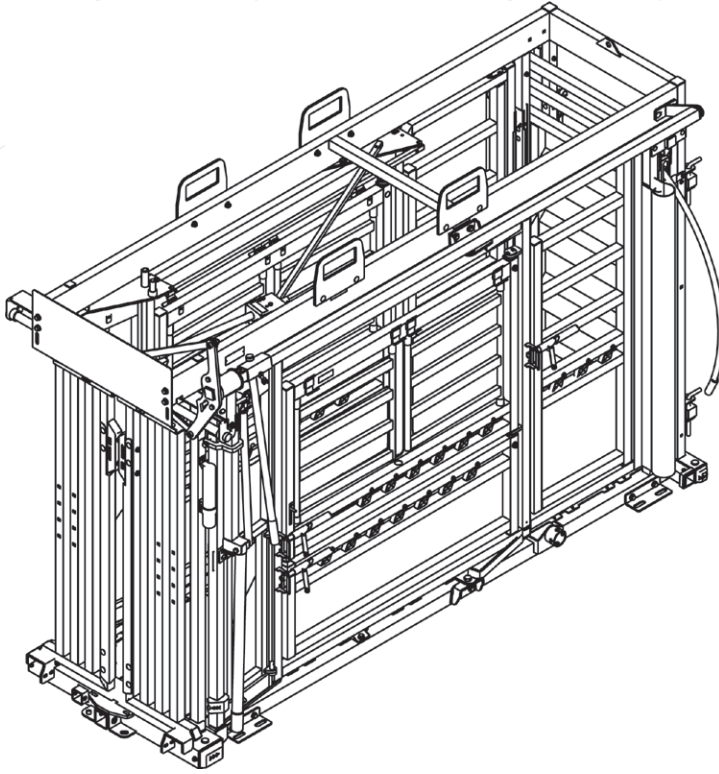

FURTHER ASSISTANCE

For further information or technical help call Arrowquip client care at 1-877-275-6075 or email cs@arrowquip.com.



